

Cooling unit for the AmpaCity project – One year successful operation



Friedhelm Herzog^{a,*}, Thomas Kutz^b, Mark Stemmler^c, Torsten Kugel^d

^a Messer Group GmbH, Gahlingspfad 31, 47803 Krefeld, Germany

^b Messer Industriegase GmbH, 65812 Bad Soden, Germany

^c Nexans Deutschland GmbH, Kabelkamp 20, 30179 Hannover, Germany

^d Westnetz GmbH an RWE Company, Altenessener Str. 35, 45141 Essen, Germany

ARTICLE INFO

Article history:

Received 28 December 2015

Received in revised form 23 March 2016

Accepted 7 April 2016

Available online 16 April 2016

Keywords:

Subcooler

Cryocooler

Superconductor

HTS-cooling system

Cryogenic cooling

AmpaCity project

ABSTRACT

High temperature super conductors (HTS) can efficiently be cooled with liquid nitrogen down to a temperature of 64 K (−209 °C). Lower temperatures are not practical, because at 63 K (−210 °C) nitrogen becomes solid. To achieve this temperature level the coolant has to be vaporized below atmospheric pressure. Messer has developed a cooling unit with an adequate vacuum subcooler, a liquid nitrogen circulation system, and a storage vessel for cooling an HTS-power cable.

Liquid nitrogen is circulated through the superconducting cable to take out the heat, and afterward it is pumped through the subcooler to be re-cooled. In the circulation system liquid nitrogen is used as a dielectric fluid and as a heat transfer medium. It stays always liquid (subcooled) and does not vaporize. On the secondary side of the subcooler liquid nitrogen from the storage vessel is used as refrigerant. It is vaporized under a pressure of 150 mbar to achieve the desired low temperatures.

The cooling unit was delivered in 2013 for the German AmpaCity project of RWE Deutschland AG, Nexans and Karlsruhe Institute of Technology. Within this project RWE and Nexans installed the worldwide longest superconducting power cable in the city of Essen, Germany. The cooling unit cools a 10 kV concentric HTS cable (40 MV A) with a length of 1000 m.

The cable is in operation since March 10th, 2014. After more than one year of practical operation many important figures from cable and cooling unit are available. These figures are discussed and a total energy balance is shown to compare liquid nitrogen cooling with alternative mechanical cooling systems.

© 2016 Elsevier Ltd. All rights reserved.

1. Introduction

High temperature super conductors (HTS) are materials which lose their electrical resistance at temperatures close to the boiling point of liquid nitrogen 77 K (−196 °C). In 1987 Georg Bednorz and Alexander Müller received the Nobel Prize for discovering this phenomenon. Today, HTS are used in cables, fault current limiters, electric motors and generators.

A new application for these materials is the almost loss free transportation of electrical energy using power cables, which allows for transportation of very large amounts of energy through relatively small cables. This is especially advantageous in large cities and industrial areas where the installation of conventional cables with copper or aluminium conductors often causes problems due to space requirements (see Fig. 1).

The first HTS cable which is integrated into a real power supply system of a major city was installed within the AmpaCity project of RWE Deutschland AG and Nexans. This worldwide longest

superconducting power cable is designed to supply the central city of Essen (Germany) with 40 MV A electrical power at a voltage of 10 kV. It was developed and manufactured by Nexans [1,2]. Messer delivered a liquid nitrogen operated cooling unit to generate cooling power for the superconductor at a temperature level of 67 K (−206 °C). The reliability of cable and cooling unit is tested within a two years monitored operation phase (from 2014 to 2016).

The AmpaCity project is accompanied by “Karlsruher Institute of Technology” (KIT) for scientific attendance and “Projekträger Jülich” (PTJ) on behalf of the German federal ministry of economics (BMWi) for public funding [3].

2. Description of the cooling unit

There are two significant technical requirements for cooling of a superconducting cable with liquid nitrogen:

- (1) The cooling temperature should be as low as possible, because the current carrying capacity of the cable increases as the temperature sinks.

* Corresponding author.

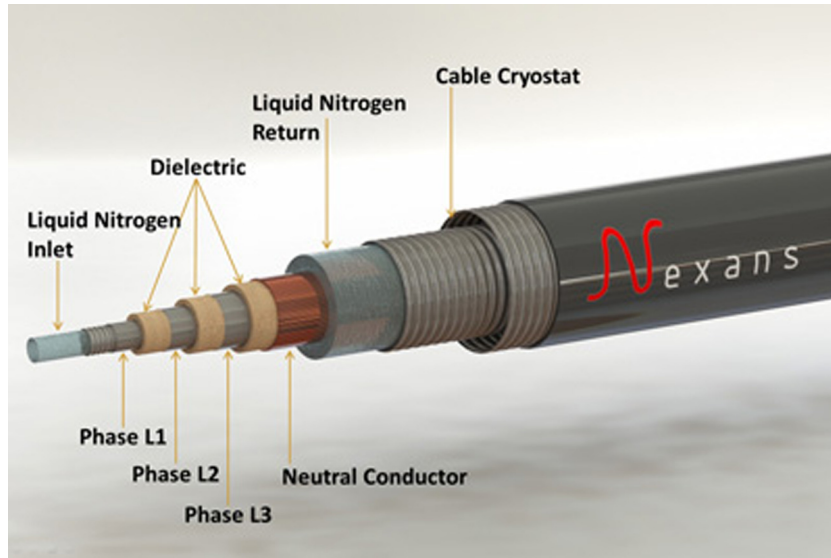

Fig. 1. Cross section of a concentric high temperature superconductor cable.

(2) The liquid nitrogen must not vaporize in the cable otherwise the loss in flow pressure will be too high and the cooling effect insufficient.

To meet these requirements the unit was designed as illustrated below (see Fig. 2):

The unit essentially consists of a subcooler, a circulation system and a liquid nitrogen storage tank. The exterior of the subcooler is filled with liquid nitrogen from the storage tank by means of an expansion valve. The nitrogen vaporizes here and creates the cooling power in the subcooler.

If the nitrogen is allowed to flow directly from the exterior of the subcooler into the atmosphere, it vaporizes at its boiling point, 77 K (−196 °C). However, this is not a sufficient cooling temperature, therefore a vacuum pump is attached to the sub-cooler so that the nitrogen vaporizes under vacuum (at 150 mbar) and the vaporizing temperature is lowered to 64 K (−209 °C). A further reduction in temperature is not possible as nitrogen freezes at 63 K (−210 °C). A sucking pressure regulation of the vacuum pump

ensures that the boiling temperature is always above the N₂ freezing point.

Inside the subcooler there is a heat exchanger through which a liquid cooling medium is pumped and cooled down to 67 K (−206 °C). Liquid nitrogen is also used as this cooling fluid, so that creation and transportation of coldness is by means of the same operating fluid. The liquid nitrogen subcooled by the heat exchanger then flows through the superconducting cable to remove the heat that has penetrated in there. While doing so the nitrogen warms slightly but remains liquid and does not vaporize. Subsequently, it is returned to the pump and subcooler where re-cooling to the operating temperature of 67 K (−206 °C) takes place. In this way a closed cooling circuit is created.

Cooling circuits using liquid fluids always need an expansion vessel to compensate for fluctuations in the volume of the coolant. A normal vessel is not suitable for this task as the gas bubble required for expansion would immediately collapse upon contact with the sub-cooled liquid. However, the nitrogen storage tank has a gas bubble which can be used as a compensating volume.

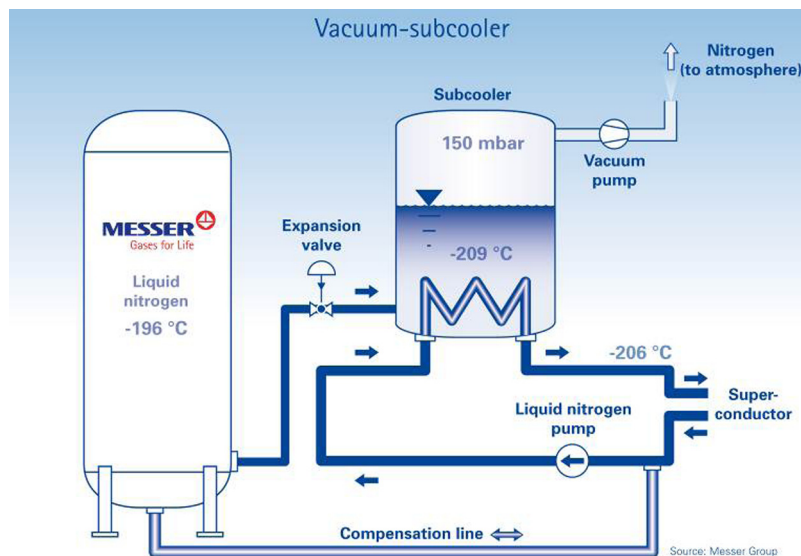

Fig. 2. Highly simplified functional diagram of the cooling unit.

By means of a technical connection between the storage tank and the cooling circuit via a suitable compensating line (including valves, sensors and cables), the storage tank can simultaneously be used as compensation vessel and becomes a functional component of the unit [4].

For safe operation of the cable it must be ensured that large amounts of nitrogen do not escape during any disruption or damage. Therefore a system should be in place to safely remove the nitrogen from the cable. The nitrogen storage tank (geometric volume: app. 50 m³) can be used for this purpose when it is connected to the cooling circuit in a suitable way.

The storage vessel thus has three functions:

- Storage of coolant
- Compensation of volume fluctuations in circulating medium
- Safeguarding of system during disturbances

The vessel can be erected away from the cooling unit to allow for easy access of the liquid nitrogen trailer. However, it is connected to the cooling unit via pipes, fittings, safety devices and signal and supply lines and is therefore an integral part of the system.

All unit components (except the storage vessel) are assembled in a steel framed container and are completely piped, wired and insulated. The vacuum pump has its own frame. These skids are fully-functional units which are thoroughly tested by the manufacturer. Thus on-site installation and commissioning can be done fast and efficient (see Fig. 3).

3. Further details

3.1. Cooling circuit/subcooler

Circulation of the liquid (subcooled) nitrogen is ensured by a low-loss-insulated pump. The suction pressure is set to 6 bar_g. This is far away from boiling conditions and so there is no cavitation problem. To guarantee the best possible unit availability the cryogenic circulating pump is designed with a backup system. If the pump malfunctions during operation the standby system automatically comes into operation.

3.2. Vacuum pump station

The vacuum in the subcooler is produced by vacuum pumps. The capacity of the cooling circuit can be adjusted energy

efficiently for the actual demand using a frequency converter which reduces electricity consumption at lower capacity demand. There are three vacuum pumps (identical in construction, power consumption: app. 5 kW per pump at 150 mbar). Each pump can cover 50% of the design capacity, therefore if one should break down, full capacity is still available. If two vacuum pumps break down at the same time the circuit temperature will increase by app. 4 K because the sucking pressure rises to app. 290 mbar which corresponds to a nitrogen vaporization temperature of 68 K (4 K above design).

The sub-cooler can also be operated when the vacuum pumps are switched off. In this case the nitrogen vaporizes at atmospheric pressure and boils at 77 K (−196 °C). The circuit temperature is then app. 14 K higher than at regular operation (see Fig. 4).

The installation of 2 circulation pumps (instead of 1) and 3 vacuum pumps (instead of 2) causes additional costs of less than 5% of the investment, but it creates an almost full redundancy of the cooling unit and a very high reliability.

3.3. Storage vessel for liquid nitrogen

The liquid nitrogen used as the circulating and cooling medium is stored at slight over-pressure (adjustable between 2 and 6 bar_g) in a cryogenic storage vessel which is equipped with high quality vacuum insulation. Additional features are a vacuum isolated liquid withdrawal connection at the lower part of the inner vessel, a controllable pressure build-up system, a high-volume return conduit into the gas compartment in case of breakdowns, as well as safety valves with a large cross section (see Fig. 5).

4. System operation

The HTS system is in operation since March 10th, 2014. The cooling unit has to be serviced twice a year. Due to the reserve pumps this can be carried out during operation, the system does not need to be switched off. If a malfunction occurs in a circulating or vacuum pump between maintenance intervals, there is an automatic switch over to one of the reserve pumps so that interruption free operation is possible for several years (see Fig. 6).

After more than one year of practical operation many important figures from cable and cooling unit are available.

The subcooler of the cooling unit has to compensate the heat impact of the cable (mainly the insulation losses of the cable cryostat, the amount of heat produced by the electrical current is quite small) and the heat impact of the cooling unit itself. The unit was designed to deliver a net-cooling capacity of 4 kW for the cable at an operating temperature of 67 K (−206 °C). This includes a reserve for unforeseen heat impacts. After start up it turned out that the cooling capacity demand for the cable at the actual operation point is app. 55% below the design point which leads to app. 40% less nitrogen and 30% less electricity consumption (details: see Table 1 below).

If the cable is bypassed (that means: no nitrogen flow through the cable and no heat impact from the cable) the internal losses of the cooling system (mainly the heat impact from the circulation pump, insulation losses are quite low) can be determined. These losses cause a liquid nitrogen consumption of 32 kg/h which corresponds to a cooling capacity of 1.6 kW. That means the total cooling capacity demand (gross cooling capacity) for the cable including the compensation of heat impact from circulation pumps and insulation losses of the cooling unit is (1.8 kW + 1.6 kW) = 3.4 kW (see Fig. 7).

As can be seen from the diagram the electricity consumption for the vacuum pumps is an exponential function of the cooling demand, due to the frequency drives of the pump motors which



Fig. 3. Cooling unit, performance test at the manufacturer (Krytem GmbH, Willich).

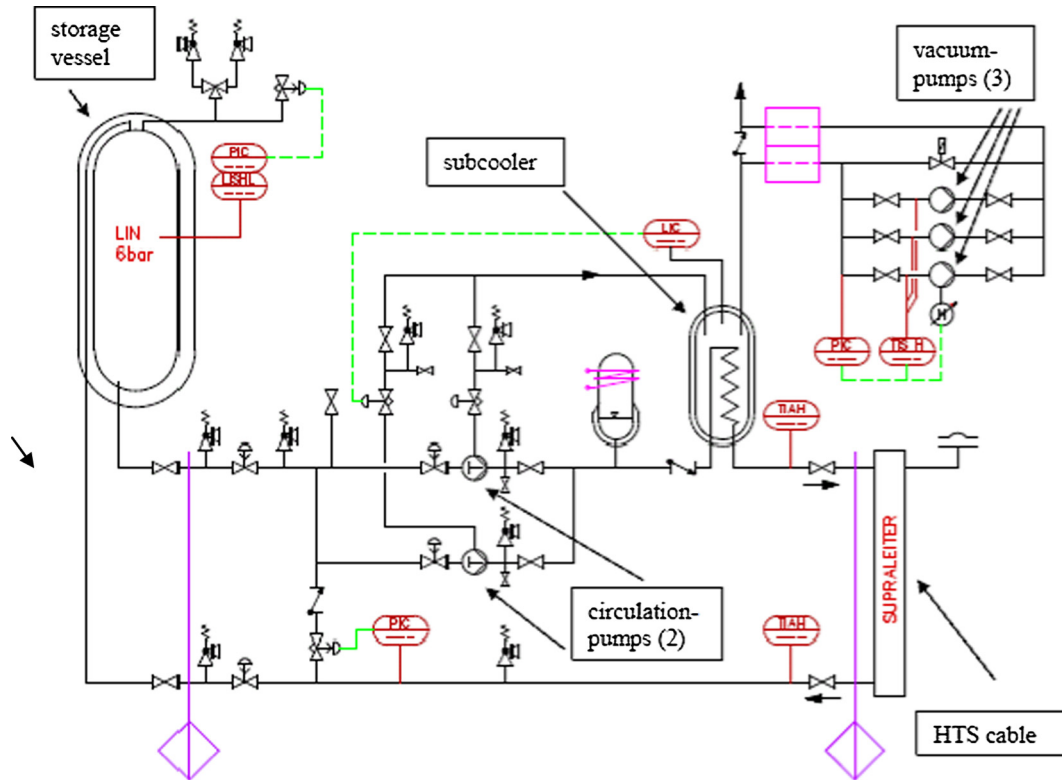

Fig. 4. Layout of cooling circuit with connection to storage vessel and superconductor (simplified representation).



Fig. 5. Cooling RWE substation in Essen, Germany – delivery and installation of the liquid nitrogen vessel.

cause losses at partial capacity operation. At regular operation 2 pumps are working at 50% capacity. If the unit is operated with only 1 vacuum pump at 100% capacity the electricity consumption could be reduced by app. 2 kW.

The liquid nitrogen consumption is (almost) linear dependent on the cooling capacity demand of the cable and proportional dependent on the total cooling capacity (not shown in the diagram). This is understandable because the subcooler's heat exchange surface area is app. 50% oversized and during operation

the capacity limit is not reached. Cooling capacity is only limited by the sucking capacity of the vacuum pumps.

The coldness is generated in the subcooler by vaporizing liquid nitrogen at a temperature of 64 K (−209 °C), very close to the N₂ freezing point. So there is a maximum driving force of 3 K for the heat transfer from the circulating liquid nitrogen to the vaporizing coolant (see Table 2).

Because of the oversized heat exchange surface area of the subcooler the requested nitrogen circulation temperature of 67 K



Fig. 6. Cooling unit installed at RWE substation in Essen (Germany), ready for operation.

is practically already achieved at an evaporation temperature of 66 K at regular operation and 65 K during operation at the design point. This is only a small temperature effect, but because the evaporation pressure of nitrogen is an exponential function of the temperature the operating conditions for the vacuum pumps become quite a bit more advantageous and it is possible to run the unit at the regular operation point with only 1 vacuum pump.

5. Cumulative energy balance

Nitrogen for the AmpaCity installation is liquefied in Messer's air separation unit (ASU) in the city of Siegen. The electricity needed for liquefying nitrogen can be calculated with 0.48 kW h/kg. The exergetic effect of liquid nitrogen transport (distance: 130 km) can be assumed with a value of 0.02 kW h/kg. Energy demand for air separation is not taken into account because nitrogen for liquefaction is taken from the excess nitrogen stream of the ASU which is regularly vented back to the atmosphere.

If the energy consumptions for cooling unit, nitrogen liquefaction and transport are summarized, 43 kW electrical power is needed for providing 3.4 kW total cooling capacity (actual requirement of the installation at 1.8 kW cooling capacity demand for the cable). In comparison 3.4 kW cooling capacity at 67 K (or even 3 K below) generated by a cooling machine affords electrical power of app. 75–100 kW (dependant on the availability of cooling water).

From the energetic point of view the environmental impact of the liquid nitrogen cooling unit for the HTS cable system is more or less half as relevant as the impact of a comparable mechanical cooling system.

Table 1
Liquid nitrogen and electricity consumption of the cooling unit.

	Cooling demand (cable) (kW)	Liquid nitrogen consumption (kg/h)	$P_{el.}$ vacuum pumps (kW)	$P_{el.}$ other components (kW)	$P_{el.}$ total (kW)
Design	4.0	110	9	4	13
Regular operation	1.8	68	5		9
Cable-bypassed	0.0	32	3		7

liquid nitrogen and electricity consumption

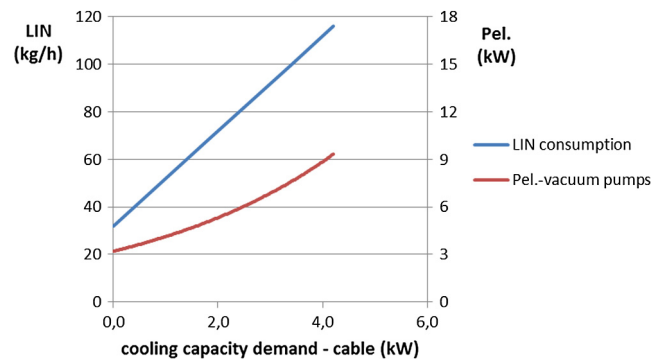

Fig. 7. Liquid nitrogen consumption and electricity demand of the vacuum pumps for generation of coldness.

Table 2
Cooling capacity and temperature.

	Cooling demand (cable) (kW)	Temperature of circulating nitrogen	Total cooling capacity (subcooler) (kW)	Min. evaporation temperature in the subcooler
Design	4.0	67 K (−206 °C)	5.6	64 K (−209 °C)
Regular operation	1.8		3.4	
Cable-bypassed	0.0		1.6	

6. Conclusion

Within the AmpaCity project a 40 MV A HTS cable system was successfully commissioned in March 2014. The cable is cooled by a highly reliable cooling unit which delivers is able to deliver coldness at a temperature of 67 K (−206 °C). The coldness is generated in a subcooler by vaporizing liquid nitrogen at a temperature of 64 K (−209 °C), very close to the N_2 freezing point. The reliability of cable and cooling unit is tested within a two years monitored operation phase (from 2014 to 2016). Actual results show that the installation can be operated without disturbances over very long time periods. Electricity and liquid nitrogen consumptions are in the expected range and allow a quite economical operation of the installation.

Acknowledgements

The authors want to thank all members of the AmpaCity project team for delivering the basic figures for this article and for their great cooperation during set up, testing and operating of the installation.

References

- [1] Stemmler M, Merschel F, Noe M, et al. Novel grid concepts for urban area power supply. *Phys Procedia* 2012;36:884–9.
- [2] Schmidt F, Maguire J, Welsh T, et al. Operation experience and further development of a high-temperature superconducting power cable in the long island power authority grid. *Phys Procedia* 2012;36:1137–44.
- [3] Goldacker W, Heller R, Hofmann A, et al. Development of superconducting and cryogenic technology in the Institute for Technical Physics (ITP) of the Research Center Karlsruhe. *Cryogenics* 2002;42(12):735–70.
- [4] Herzog F, Kutz T. Cooling unit for superconducting electricity cables. In: *Proceedings of the 13th IRR international conference on cryogenics*, 2014. p. 99–105.